

Automatic road
barriers
for passage of
widths up to
7.6 m / 24.9 ft

new GARD 8

A new concept of automatic barrier

Innovation and design for all-inclusive security: these are the most recent additions to the GARD barrier line family. Soft contours and rounded corners to counteract the “sail effect” for a barrier that incorporates perfectly into a diversity of installation settings.



CAME
AUTOMATIC GATES

GARD8

230V 24V

Automatic road barriers

Designed for a range of large openings up to 7,6 m / 24.9 ft, the new GARD barriers are the ideal solution for control of roads and parking areas for industrial and public use.

The GARD series is available in the 110V/230V AC motor and the 24V DC motor versions.

The new series offers many new features, all marked by innovation.

A blend of design and modern technology of illumination: the exclusive incorporated flashing light with a lighted LED diffuser needs no special maintenance and ensures complete visibility of the warning light.

The protective guard on the bar is a standard feature to protect the user from possible risk when the bar is in rotation.

Integration luminous cord: superior visibility of the bar and maximum durability of the light fixtures.

Round tubular bar: for maximum reduction of the sail effect ensuring correct functioning even in areas subject to high winds.

Intermittent lighted cable cord: superior visibility of the bar and maximum durability of the light fixtures.

Command electronics: protected by a die-cast aluminium guard, it is positioned to make any type of intervention extremely practical.

Command electronics: an electronic contact automatically interrupts the power supply voltage as soon as the inspection door is opened.

Differentiated sensitivity spring: for exceptional balancing of the bar.

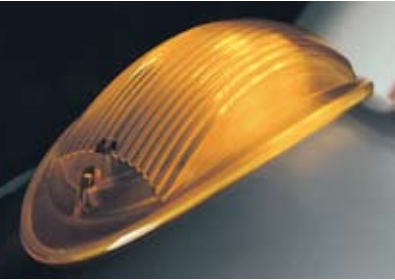



Electronics

The GARD series barriers are constructed with next-generation electronic controls that guarantee total control of the automatic system, improving and increasing the usual safety and control functions, such as:

- > **comprehensive AUTOTEST** of all the safety devices connected to the system prior to activating the motor (electronic autotest).
- > **electronic control of the movement** of the bar with obstruction detection (anti-crushing function).
- > **a safety feature even when the bar is stationary:** all controls are invalidated if an obstruction is detected by the safety devices.

24V barriers

Streets, parking areas, collective areas or simply specific functional and security needs of the system can call for the use of a GARD system with 24V technology.

> Frequent black outs

The electronics of a GARD24 system automatically recognize a lack of power and activate emergency operation with special auxiliary batteries.

> Keep speed in check

For total service, the 24V electronics enable the operating speed to be adjusted depending on whether the situation requires faster or slower openings and closings.

> Intensive traffic

The low-voltage motor ensures operation of the barrier for intensive traffic conditions, such as streets, parking areas and other areas entailing constant, intensive operation.

> Rapid transit

The 24V technology regulates the barrier opening time between 8 and 4 seconds.



Also available as a set or with synchronous action

Thanks to the additional RSE card the barriers can be installed facing each other or be synchronised with the "compass" function at the same access point.



Global entry control

Also available as a set or with synchronous action. Thanks to the additional RSE card the barriers can be installed facing each other or be synchronised with the "compass" function at the same access point.



Made in Italy



For its quality processes management Came Cancelli Automatici is ISO 9001:2000 certified, and for its environmental management it is ISO 14001 certified. Came designs and manufactures entirely in Italy.

The models

230V Barriers

- G2081** Automatic barrier in zinc plated or coated steel with 230V A.C. gearmotor complete with casing and control board transformer
- G2081I** Automatic barrier in brushed AISI 304 stainless steel with 230V A.C. gearmotor complete with casing and control board transformer

230V Electronics

- ZG5** Extra electronic board designed with a socket for CAME radio cards
- ZG6** Basic circuit board designed with a socket for CAME radio cards
- RSE** Function management control board (for ZG5)

24V Barriers

- G2080** Automatic barrier in painted galvanized steel with 24V D.C. gearmotor complete with casing and control board transformer
- G2080I** Automatic barrier in satin-finish AISI 304 stainless steel with 24V D.C. gearmotor complete with casing and control board transformer

24V Electronics

- ZL38** Electronic card fitted to connect with radio frequency cards
- LB38** Card for connecting three 12V-7Ah emergency batteries

Technical information:

Type	230V G2081 / G2081I	24V G2080 / G2080I
Degree of protection	IP54	
Power supply (50-60Hz)	230 V A.C.	
Motor power supply	230 V (50-60Hz)	24 V D.C.
Power	330W	300W
Absorbed input	2,8 A	15A
Reduction ratio	1/202	
Max torque	250 Nm	600 Nm
Opening time	8 s	4.8 s
Operating intermittence	30%	intensive use
Operating temperature	-20°C ÷ + 55°C	

General product information:

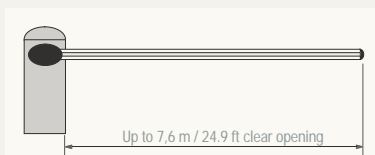

Composition of the bar

- Bar
- Bar with mobile support
- Bar with luminous cord
- Bar with luminous cord and mobile support
- Bar with rack
- Bar with rack and luminous cord

Width of passage

- 7.6 m / 24.9 ft
- 7 m / 23 ft
- 7.6 m / 24.9 ft
- 7 m / 23 ft
- 7 m / 23 ft
- 7 m / 23 ft

Dimensions:

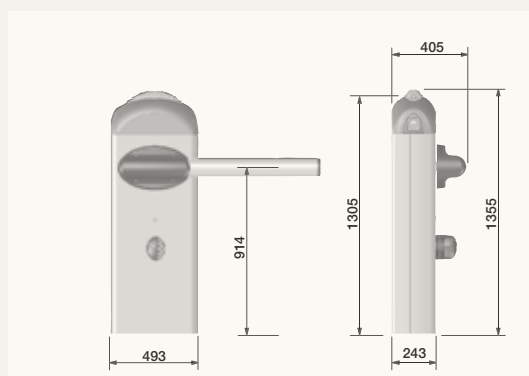

Came
cancelli automatici
s.p.a.

via Martiri della Libertà, 15
31030 Dosson di Casier
Treviso - Italy

www.came.it - info@came.it